



Western Valve

Enhanced Performance in Double Block and Bleed and Double Isolation and Bleed Valves

DAN-EX

Dual Expanding Plug Valve

MADE IN THE USA

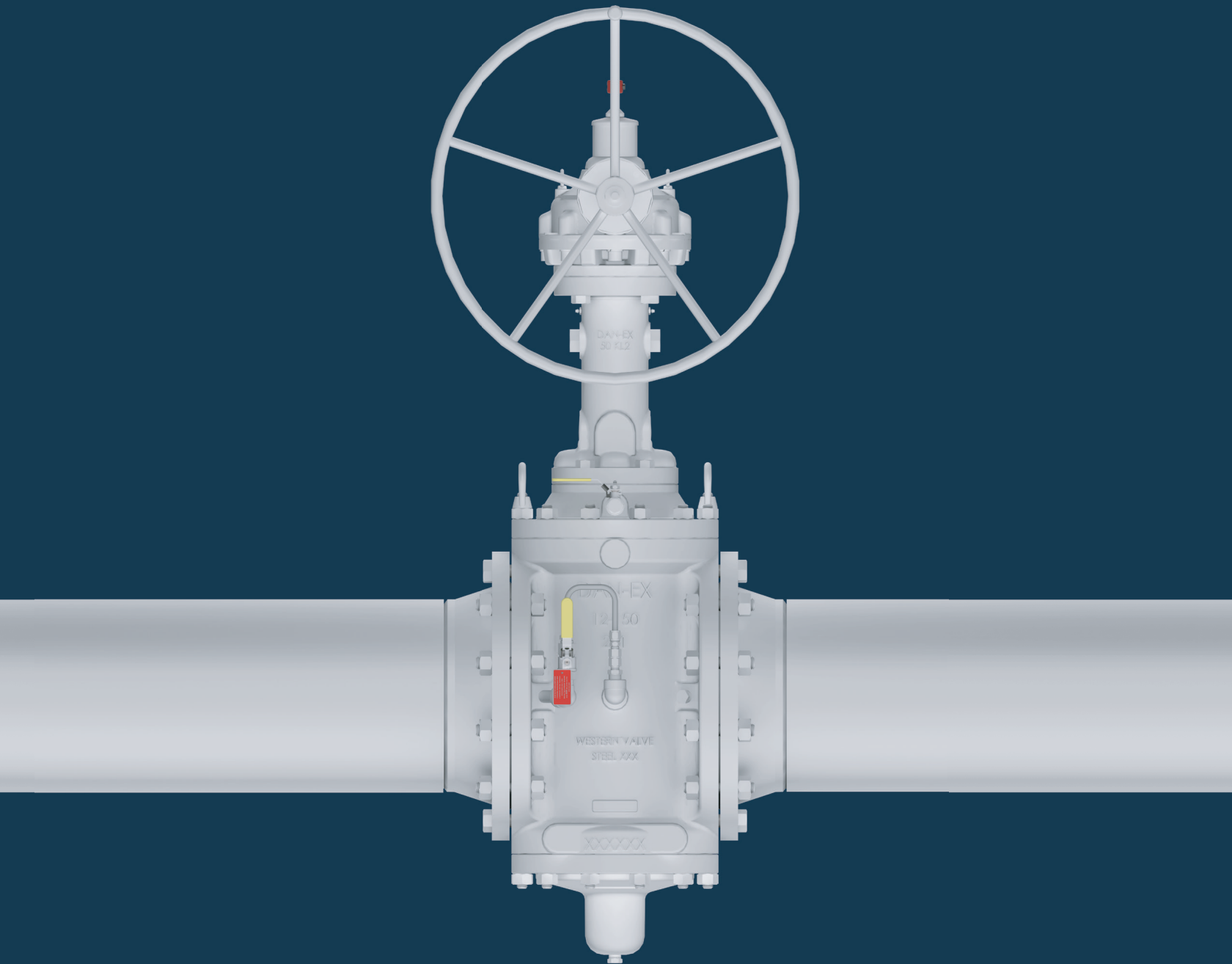

Table of Contents

DAN-EX Double Block and Bleed.....	3
Resilient Seal... ..	4
Sectional View and Features... ..	5
How DAN-EX works... ..	7

Dimensional Data

Handwheel Operated – Reduced Port.....	8
Gear Operated – Reduced Port... ..	9
Gear Operated – Reduced Round Port.....	10
Gear Operated – Full Port Piggable... ..	11

Materials of Construction and Trim Selection... ..	12
Body Bleed and Thermal Relief Valve Options.....	13
Extensions and Actuation.....	15
Limit Switch.....	16
Applications.	17

WESTERN VALVE - DOUBLE ISOLATION/DOUBLE BLOCK & BLEED

Facility

Located in Bakersfield California – Western Valve, Inc. was established in 1991. What started out as a valve repair and machine shop now features an impressive 65,000 square foot state of the art manufacturing facility on five acres.



Verifiable Double Isolation/Double Block and Bleed Feature

All DAN-EX Valves combine the upstream and downstream seals with a bleed cavity between the sealing slips. The use of a manual bleed valve verifies zero leakage in either direction – at any pressure – from atmospheric up to the full working pressure exerted on either side of the valve.

Double Block And Bleed

The double block and bleed requires the use of two block valves separated by a spool. The bleed valve is used to drain the spool when both valves are closed, to prevent leakage from high pressure line into the lower pressure line.

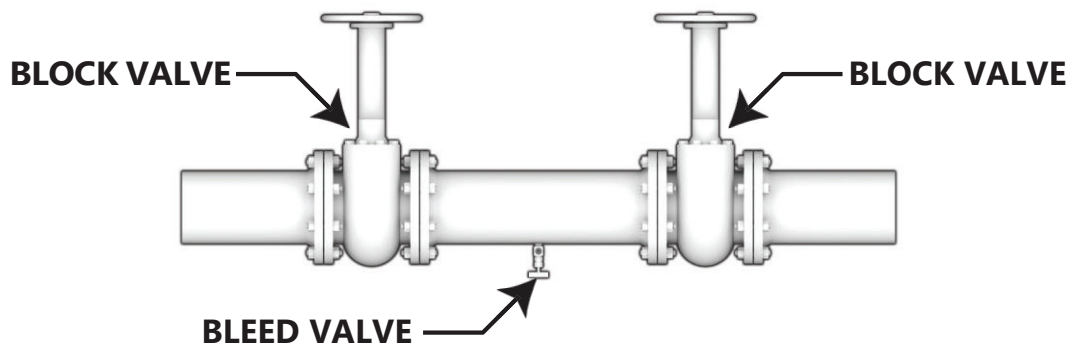

DAN-EX valves supplies the same function as the conventional block and bleed, but without loss through the open bleed.

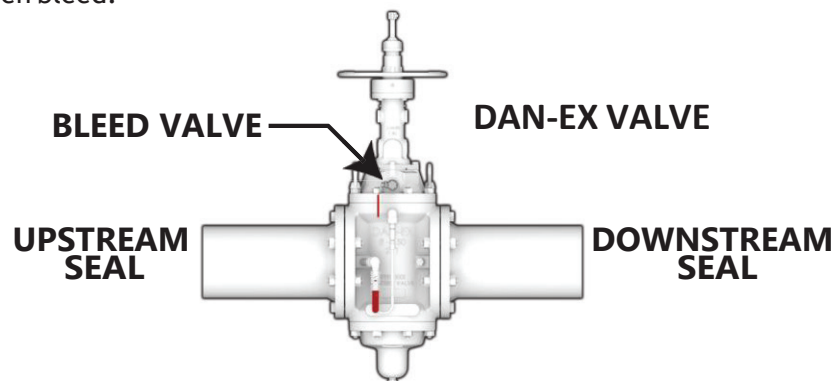

The upstream and downstream seals supply the same function as the two block valves, and the body bleed verifies that both seals are holding tight.

RESILIENT SEAL

Mechanical Perpendicular Seat Action

Mechanical operation of the DAN-EX Valve plug forces the seating slips into a perpendicular wedging action driving the seals against the valve body sealing surfaces. Upon opening, the plug dovetail connections retract the slips from the sealing surface in a perpendicular direction with no abrasive action on the seals.

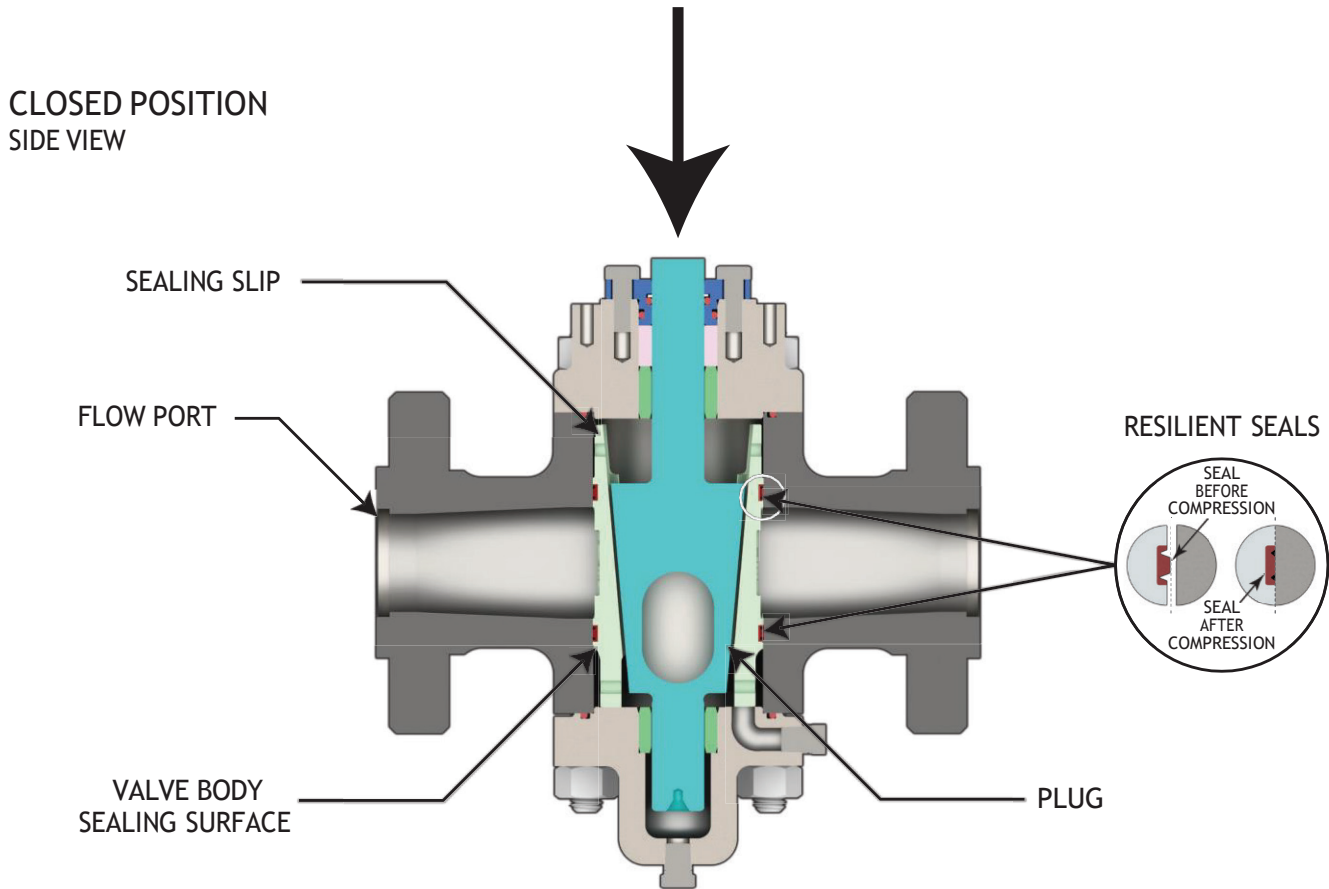

Fire-Safe Protection with Metal-to-Metal Seating

The resilient seals are compressed to provide a metal-to-metal seal between the slip and body providing a seal sufficient to prevent the line media from adding to a fire.

Replaceable Seals

The valve slips can be removed for seal inspection and changed in the line from either top or bottom, following line depressurization and drainage. Western Valve offers a slip exchange program. Contact us for details.

SECTIONAL VIEW & FEATURES

1. Handwheel:

Includes spinner handle for fast and easy valve operation.

2. Cam Shaft:

One Piece camshaft – precision machined from 4140 and heat treated for superior strength and wear resistance – featuring dual “S” cam slots for smooth trouble free operation.

3. Manual Body Bleed Valve:

Used to verify seal integrity when the valve is closed.

4. Differential Thermal Relief (DTR):

Automatically relieves pressure from the body cavity caused by solar or ambient temperature changes.

5. Valve Body:

ASTM A-216 WCC carbon steel body with chrome plated seating areas. Larger sizes include cast support ribs for increased strength.

6. Bonnet and Lower Plate:

Sizes 3” through 30” slips can be removed through top or bottom of valve.

7. Solid Carbon Steel Plug with Integral Upper and Lower Trunnions:

Solid one-piece plug features large diameter trunnions integral to the plug for superior strength. These large trunnions are fully extended and supported by bonnet and lower plate bushings to eliminate flex under full line pressure.

8. Bushing:

Precision Ni-resist bushings are installed in both bonnet and lower plate. These bushings provide two essential functions: hold and support plug

trunnion “on center” and extend the life of the valve by reducing wear.

9. Seating Slips:

Western Valve’s in house bonding facility incorporates proven technology and procedures to ensure quality bonds for slip bonding. This key process is critical to ensuring quality bonds in the key component known as the “heart of the valve”. The technology and procedures used result in years of reliable slip performance.

10. Packing:

Graphite High Cycle Stem Packing

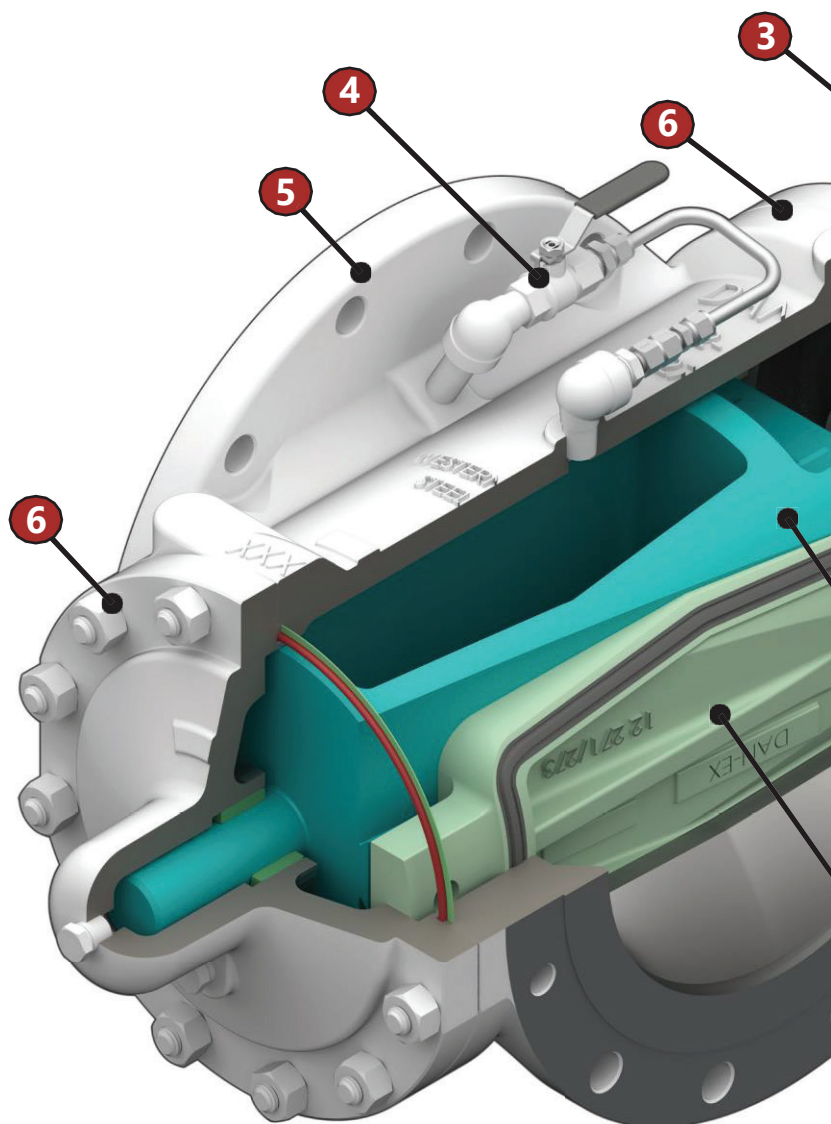

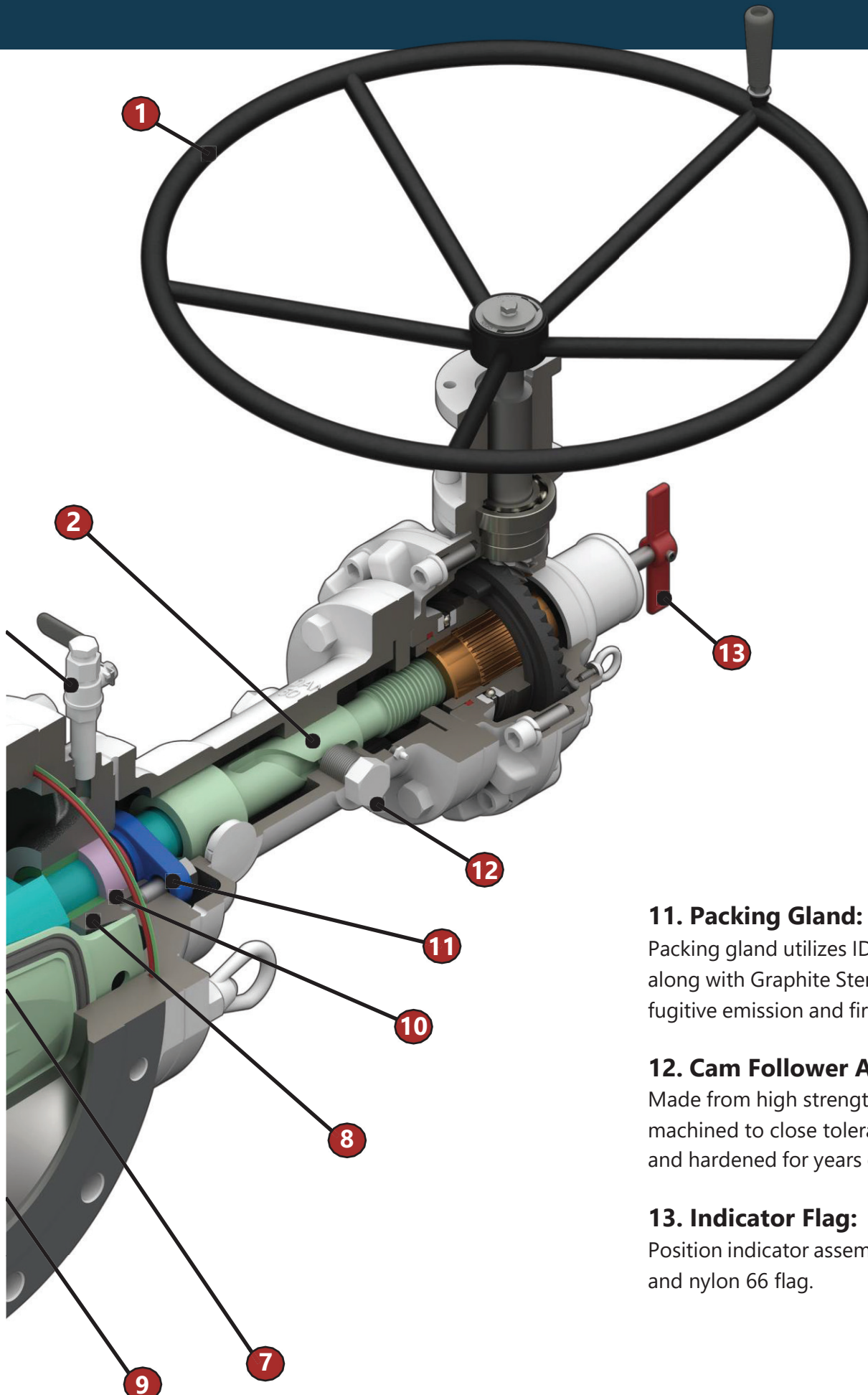

11. Packing Gland:

Packing gland utilizes ID and OD o-ring seals along with Graphite Stem Packing to exceed fugitive emission and fire safe standards.

12. Cam Follower Assembly:

Made from high strength materials and machined to close tolerances, precision ground, and hardened for years of trouble free operation.

13. Indicator Flag:

Position indicator assembly includes a SST shaft and nylon 66 flag.

HOW THE DAN-EX DUAL EXPANDING PLUG VALVE WORKS

TOP VIEW

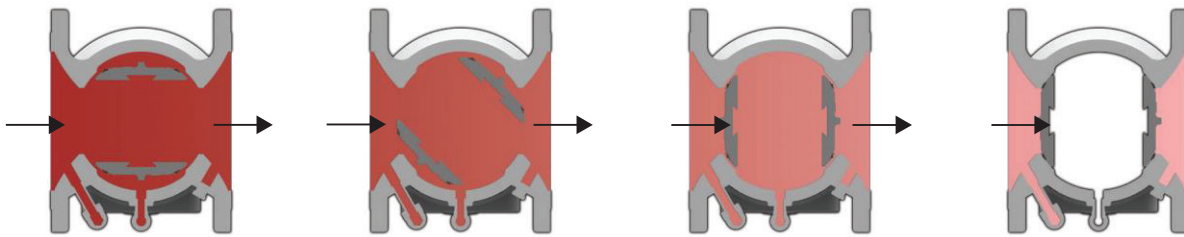

OPEN



ROTATING



EXPANDING



CLOSED

Open View

In the fully open position, the tapered plug is lifted all the way up. The slips are held to the plug via dovetails. Slips are fully retracted away from the valve body. In addition, the slips are protected from the flow.

Closing/Rotating View

Turning the handwheel clockwise begins to rotate the plug/slip assembly 90 degrees. During this rotation, slips maintain clearance from the body, therefore eliminating scoring/rubbing against the body during the full 90 degree rotation. During valve operation, the plug/slip assembly is held securely on centerline of the body by the use of large diameter upper and lower plug trunnions along with bushings installed in the bonnet and lower plate.

Expanding View

The plug/slip assembly has rotated 90 degrees and as the taper plug begins to move downward, an expanding/wedging action begins to force the slips against the body seating area.

Fully Closed View

When the valve is fully closed and the slips are fully seated, the slip seal compresses into "as molded grooves" to provide a 100% verifiable Double Block and Bleed shutoff as well as secondary metal to metal firesafe seal for both upstream and downstream closure. The valve is bidirectional and does not rely on springs or flow for shutoff.

DIMENSIONAL DATA

HANDWHEEL OPERATED - REDUCED PORT

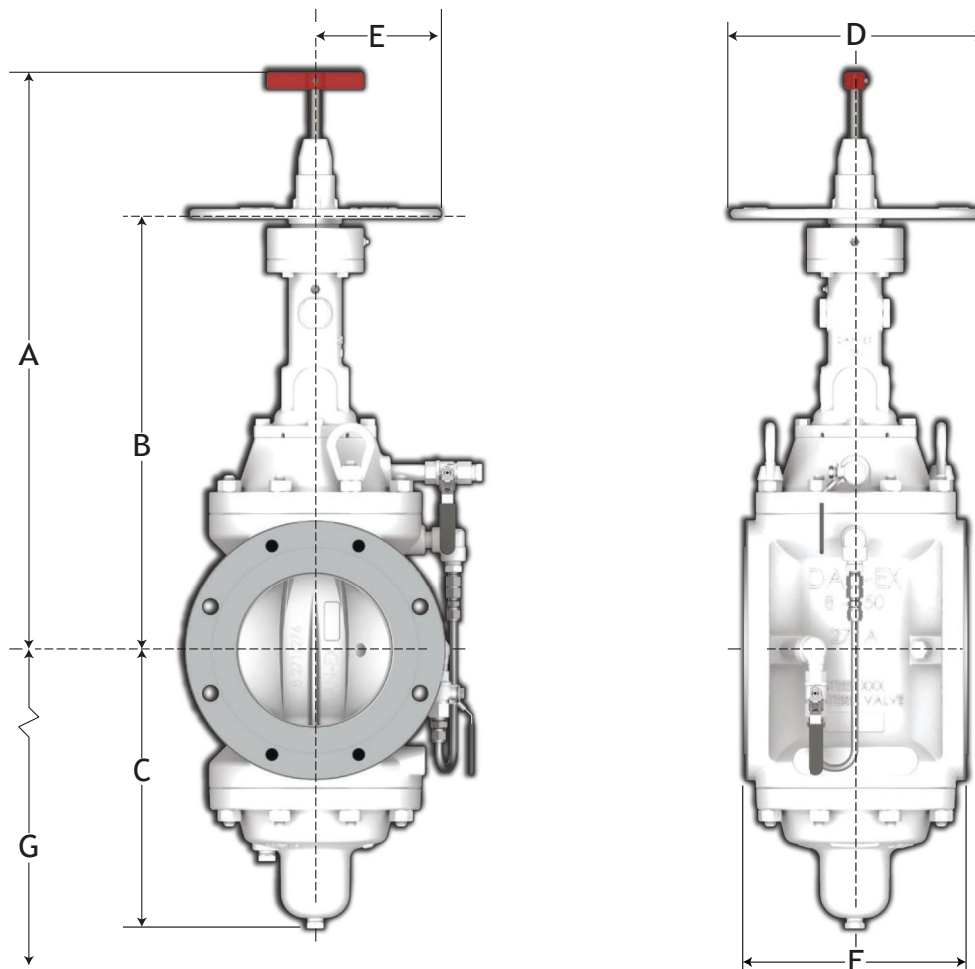

Dimensions In.				Maximum Overall Height From Centerline	Centerline of Valve to Centerline of Hand-wheel	Centerline of Valve to Lowest Point	Hand-wheel Diameter	Centerline of Valve to Outside of Hand-wheel	Face to Face	Minimum Clearance Required to Replace Slips From Centerline	Approximate Weight
Class	Size	Figure	Operator	A	B	C	D	E	F	G	Lbs.
ASME 150	2	271A	5KL	17 7/8	10 17/32	3 1/4	10	5	7	N/A	58
	3	271	10KL	25 7/32	17 7/8	8 1/16	13	6 1/2	8	12 3/16	151
	4	271	10KL	25 7/32	17 7/8	8 1/16	13	6 1/2	9	12 3/16	154
	6	271C	10KL	27 5/32	19 25/32	10	13	6 1/2	10 1/2	20 3/32	256
	8	271C	10KL	27 29/32	20 9/16	11 15/32	13	6 1/2	11 1/2	19	315
ASME 300	2	273	5KL	17 7/8	10 17/32	6 7/32	10	5	8 1/2	8 1/4	68
	3	273	10KL	25 1/2	17 23/32	8	13	6 1/2	11 1/8	12 3/16	163
	4	273	10KL	25 1/2	17 23/32	8	13	6 1/2	12	12 3/16	192
ASME 600	2	275	5KL	17 7/8	10 17/32	6 3/16	13	6 1/2	11 1/2	8 1/4	89
	3	275	10KL	25 15/16	18 7/32	8 5/16	13	6 1/2	14	12 3/16	231
	4	275	10KL	25 15/16	18 7/32	8 5/16	13	6 1/2	17	12 3/16	279

DIMENSIONAL DATA

GEAR OPERATED - REDUCED PORT

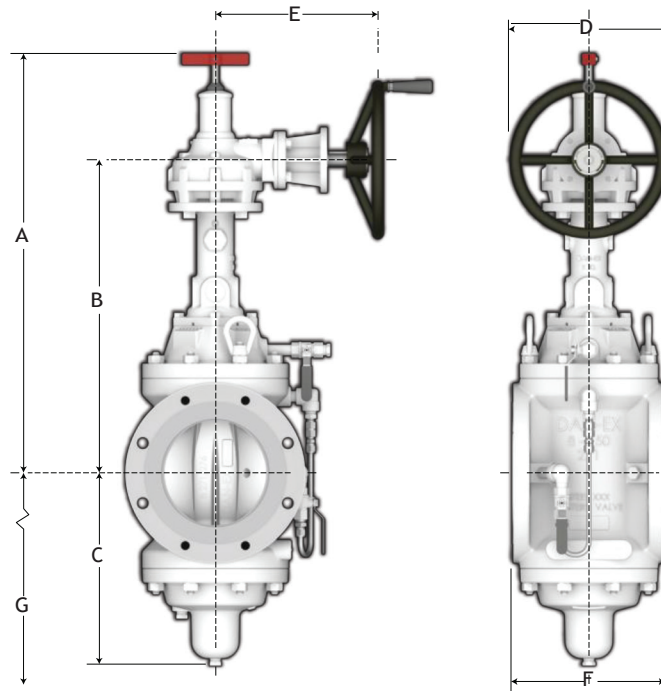

Dimensions In.				Maximum Overall Height From Centerline	Centerline of Valve to Centerline of Hand-wheel	Centerline of Valve to Lowest Point	Hand-wheel Diameter	Centerline of Valve to Centerline of Hand-wheel	Face to Face	Minimum Clearance Required to Replace Slips From Centerline	Approximate Weight
Class	Size	Figure	Operator	A	B	C	D	E	F	G	Lbs.
ASME 150	3	271	10KL	28 1/2	18 11/16	8 1/16	11.81	12 3/16	8	12 3/16	206
	4	271	10KL	28 1/2	18 11/16	8 1/16	11.81	12 3/16	9	12 3/16	219
	6	271C	10KL	30 5/32	20 19/32	10	11.81	12 3/16	10 1/2	20 3/32	288
	8	271C	10KL	30 29/32	21 3/8	11 15/32	11.81	12 3/16	11 1/2	19	346
	10	271	50KL3	42 9/16	32 1/32	16 11/16	17.72	14 29/32	13	28 31/32	728
	12	271	50KL3	43 3/8	32 27/32	17 1/2	24.81	15 21/32	14	31 1/2	890
	14	271	50KL3	43 3/8	32 27/32	17 1/2	24.81	15 21/32	15	31 1/2	964
	16	271	50KL3	47	36 5/32	22 3/8	24.81	15 21/32	16	40 1/2	1431
	18	271	50KL3	47	36 5/32	22 3/8	24.81	15 21/32	17	40 1/2	1570
	20	261	50KL3	44 5/16	36 9/16	22 5/16	31.5	16 9/32	18	40 1/2	1571
	20	271	50KL3	45 5/8	35 9/32	23 1/8	31.50	16 9/32	21 1/2	43 1/8	1875
	20	271C	50KL3	45 5/8	35 9/32	23 1/8	31.50	16 9/32	32	43 1/8	1875
	24	261	50KL3	46 1/32	35 29/32	23 3/4	31.50	16 9/32	20	43 1/8	2061
	24	271	100KS2	50 7/16	42 1/16	21 3/8	30	16 11/16	36	46 15/16	3747
30	271	100KS2	50 7/16	42 1/16	21 1/16	30	16 11/16	36	46 15/16	4333	
ASME 300	3	273	10KL	28 1/2	18 11/16	8	11.81	12 3/16	11 1/8	12 3/16	222
	4	273	10KL	28 1/2	18 11/16	8	11.81	12 3/16	12	12 3/16	245
	6	273	50KL3	40 29/32	30 11/32	14 15/32	17.72	14 29/32	15 7/8	19 5/8	604
	8	273	50KL3	40 29/32	30 11/32	14 15/32	17.72	14 29/32	16 1/2	19 5/8	659
	10	273	50KL3	42 9/16	32 1/32	16 11/16	24.81	15 21/32	18	28 31/32	950
	12	273	50KL3	44 3/32	33 3/16	17 9/16	31.50	17 1/16	19 3/4	31 1/2	1171
	14	273	50KL3	44 3/32	33 3/16	17 9/16	31.50	17 1/16	30	31 1/2	1421
	16	273	100KS2	48 1/2	39 3/4	22 3/8	30	16 11/16	33	40 1/2	2220
18	273	100KS2	48 1/2	39 3/4	22 3/8	30	16 11/16	36	40 1/2	2470	
24	273	250K	62 29/32	51 3/4	21 5/8	36	24 25/32	45	46 15/16	5809	
ASME 600	3	275	10KL	28 15/16	19 3/16	8 5/16	11.81	12 3/16	14	12 3/16	296
	4	275	10KL	28 15/16	19 3/16	8 5/16	11.81	12 3/16	17	12 3/16	344
	6	275	50KL3	39 25/32	28 7/8	13 1/2	24.81	16 7/16	22	20 3/32	848
	8	275	50KL3	41 9/16	30 21/32	15 1/4	24.81	16 7/16	26	25 1/4	1037
ASME 900	3	276	10KL	28 15/16	19 3/16	8 5/16	11.81	12 3/16	14	12 3/16	287
	4	276	10KL	28 15/16	19 3/16	8 5/16	17.72	12 15/16	18	12 3/16	377
	6	276	50KL3	39 25/32	28 7/8	13 1/2	31.50	17 1/16	24	20 3/32	945
	8	276	50KL3	41 9/16	30 21/32	15 1/4	31.50	17 1/16	29	25 1/4	1178

DIMENSIONAL DATA

GEAR OPERATED - REDUCED ROUND PORT

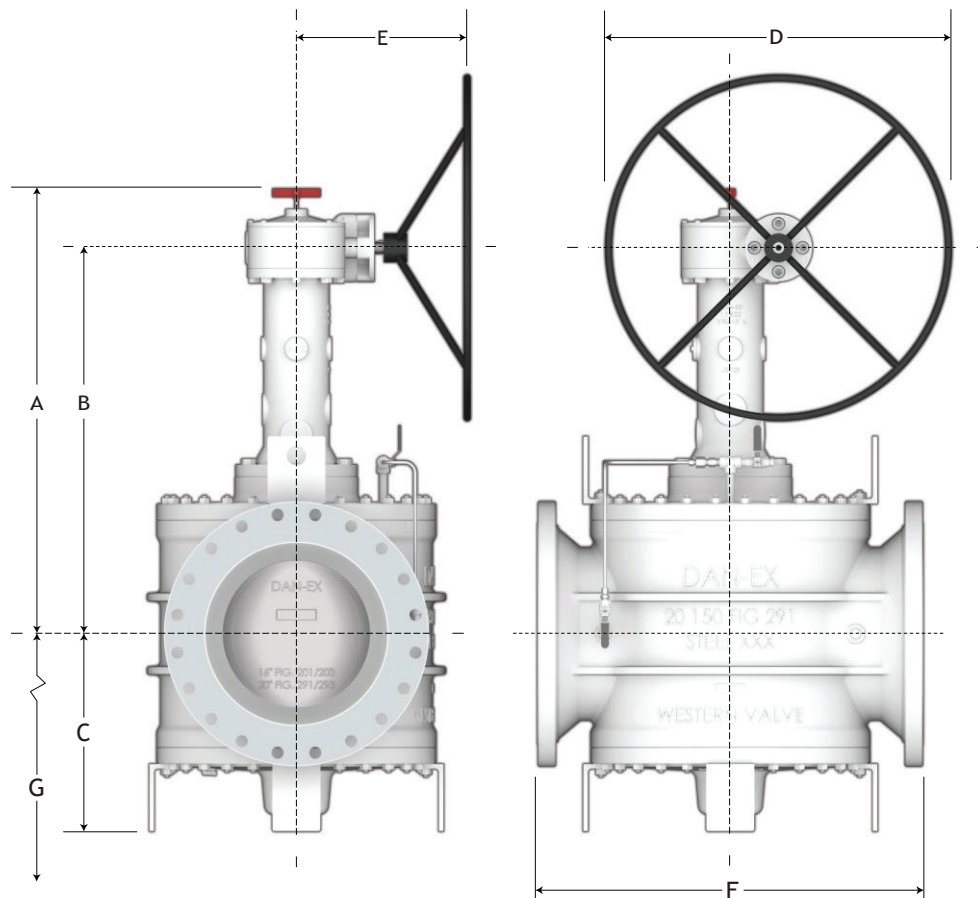

Dimensions In.				Maximum Overall Height From Centerline	Centerline of Valve to Centerline of Hand-wheel	Centerline of Valve to Lowest Point	Hand-wheel Diameter	Centerline of Valve to Centerline of Hand-wheel	Face to Face	Minimum Clearance Required to Replace Slips From Centerline	Approximate Weight
Class	Size	Figure	Operator	A	B	C	D	E	F	G	Lbs.
ASME 150	20	291	100KS2	48 1/2	40 1/16	20 1/2	36	17 23/32	40	33 9/16	3537
	24	291	100KS2	52 5/16	43 13/16	23 3/4	36	17 23/32	52	38 1/2	5889
ASME 300	20	293	100KS2	49 5/32	40 3/4	21 3/8	36	17 23/32	39	33 9/16	4088
ASME 600	12	295	100KS2	46 7/8	38 3/8	18 5/8	30	16 11/16	33	24 15/16	2745
	16	295	250K	59 1/16	48	19 7/8	36	24 13/32	39	27 15/16	4449
	20	295	250K	61 1/8	50	21 3/4	36	24 13/32	47	33 9/16	6041

DIMENSIONAL DATA

GEAR OPERATED - FULL PORT PIGGABLE

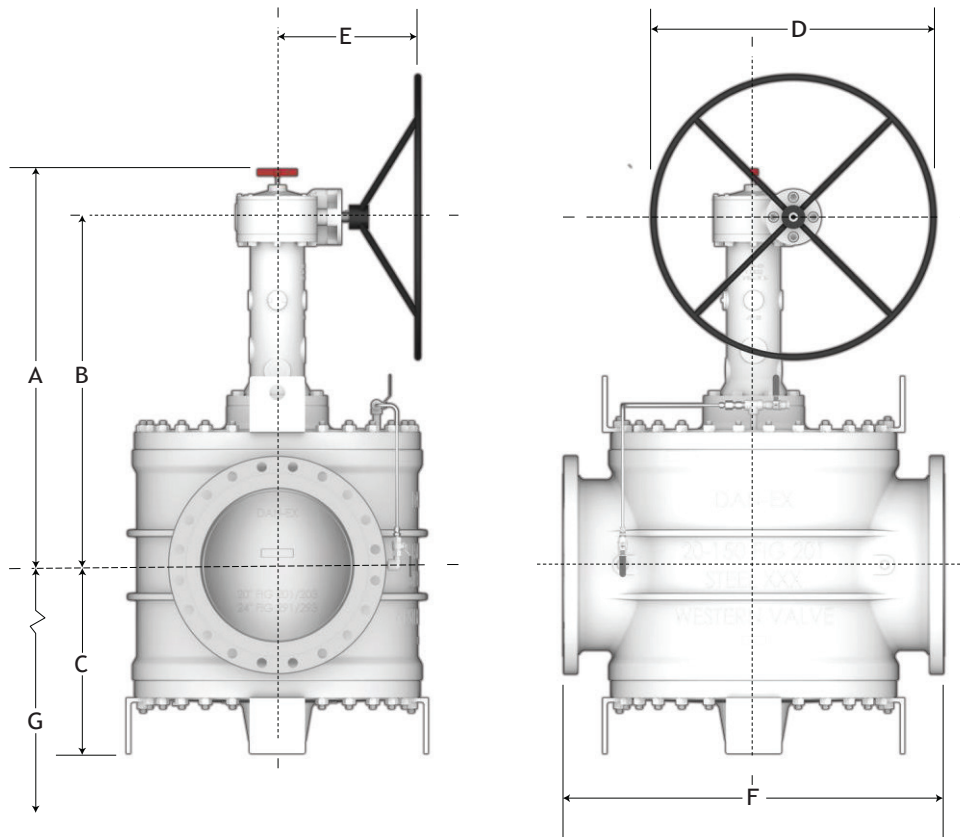

Dimensions In.				Maximum Overall Height From Centerline	Centerline of Valve to Centerline of Hand-wheel	Centerline of Valve to Lowest Point	Hand-wheel Diameter	Centerline of Valve to Centerline of Hand-wheel	Face to Face	Minimum Clearance Required to Replace Slips From Centerline	Approximate Weight
Class	Size	Figure	Operator	A	B	C	D	E	F	G	Lbs.
ASME 150	6	201	70KS	32 3/32	24 7/16	9 7/8	18	7 21/32	21	14 1/2	688
	8	201	70KS	31 23/32	25 19/32	11 1/32	18	7 21/32	25	17 5/16	826
	10	201	100KS2	42 1/4	33 7/8	16 11/32	30	16 11/16	31	24 15/16	1710
	12	201	100KS2	43 1/2	35	15 1/4	30	16 11/16	36	27 15/16	1825
	14	201	100KS2	43 5/8	35 5/32	17 19/32	36	17 23/32	34	26 5/8	2533
	16	201	100KS2	48 1/2	40 1/16	20 1/2	36	17 23/32	35	33 9/16	3222
ASME 300	6	203	70KS	52 5/16	43 13/16	23 3/4	36	17 23/32	48	38 1/2	5777
	8	203	70KS	30 5/16	24 7/32	9 7/8	18	7 21/32	22	14 1/2	804
ASME 600	8	203	70KS	31 23/32	25 19/32	11 9/32	24	7 21/32	27	15 9/16	1134
	6	205	70KS	31 29/32	24 9/32	10 3/8	18	7 21/32	22	14 11/32	896
	8	205	70KS	32 5/32	26 1/16	11 17/32	24	7 21/32	26	18 23/32	1381
	10	205	100KS2	46 7/8	38 3/8	18 5/8	36	17 23/32	31	24 15/16	2435
	12	205	250K	59 1/8	48	19 7/8	36	24 13/32	33	27 15/16	3995
	16	205	250K	61 1/8	50	21 3/4	35.43	29 3/4	39	29 1/4	5439

DAN-EX STANDARD MATERIALS OF CONSTRUCTION

	WCC SERVICE TEMPERATURE -20F to +300F (-29C to +149C)	LCC SERVICE TEMPERATURE -50F to +300F (-46C to +149C)
Body:	ASTM A-216 WCC Chrome Plated Bore	ASTM A-352 LCC Chrome Plated Bore
Bonnet:	ASTM A-216 WCC/ ASTM A-36 Plate	ASTM A-352 LCC/ ASTM A-516 GR 70
Lower Plate:	ASTM A-216 WCC/ ASTM A-36 Plate	ASTM A-352 LCC/ ASTM A-516 GR 70
Plug:	ASTM A-216 WCC Electroless Nickel Plated	ASTM A-352 LCC Electroless Nickel Plated
Slip/Seal:	ASTM A-395 GR. 60-40-18/Viton®	ASTM A-395 GR. 60-40-18/Low Temp Viton®
Trunnion Bushings:	ASTM A436 Type 1 NI-Resist	ASTM A436 Type 1 NI-Resist
O-Rings	Viton®	Low Temp Viton®
Packing Gland:	ASTM A-582 Stainless Steel/ ASTM A-487 CA6NM	ASTM A-582 Stainless Steel/ ASTM A-487 CA6NM
Stem Packing:	Grafoil Rings	Grafoil Rings
Studs:	ASTM 193 B.7	ASTM 320 L.7
Nuts:	ASTM 194 2H	ASTM 194 GR.7
Bleed System:	Differential Thermal Relief/Manual body Bleed	SST Differential Thermal Relief/Manual body Bleed
Gaskets:	Grafoil	Grafoil

TRIM SELECTION

Fluoro Elastomers Slip Seal Materials		
VT	Viton® 90 Durometer	Standard High Differential Pressure
LT VGF	Low Temp Viton® GF	Low Temp Viton® GF
VGF	Viton® GF	Viton® with Enhanced Chemical resistance
VTF	Fiber Reinforced Viton®	Optional High Differential Pressure
VTE	Viton® Extreme 90 Durometer	Viton® with Enhanced Chemical resistance
Nitrile Elastomers Slip Seal Materials		
LT NBR	Low Temp Nitrile	Low Temp Nitrile
STS	Modified Nitrile	Reformulated Gasoline Seal Material
Specialty Slip Seal materials		
EPDM	Ethylene Propylene	Ammonia but not Hydrocarbon

BODY BLEED & THERMAL RELIEF VALVE OPTIONS



DTR

Differential Thermal Relief (DTR)

Solution to dangerous pressure build up due to thermal expansion in liquid service.

The DAN-EX Dual Expanding Plug Valve is designed to provide zero leakage. Therefore, in the closed position, the center cavity of the valve is subject to extreme pressures caused by solar or ambient temperature fluctuations. In a liquid application, it is critical to protect the DAN-EX valve from this overpressure buildup prior to opening the valve. The Differential Thermal Relief system (DTR) accomplishes this task and is operational when the valve is in the closed position only.

The standard relief is set to check at 25 PSI differential and will automatically relieve the body cavity pressure back to the upstream throat of the valve. The isolation valve located in the upstream throat is to be left in the open position for the system to function. This valve is closed only when the check valve needs to be replaced. Other check pressures are available upon request.

In addition, a manual body bleed valve is provided to check the seal integrity of the DAN-EX valve when closed. The manual body bleed valve must be closed prior to opening the DAN-EX valve.

This system is to be considered standard in all applications both in manual and automated valves.



DTR w/Gauge

Differential Thermal Relief (DTR) with Gauge

Solution to seal verification without emission exposure to the atmosphere in a liquid service.

This system functions as a standard DTR system with the addition of a gauge installed prior to the manual body bleed valve. In a liquid service, the gauge will indicate a drop in pressure due to slip expansion when closed which will prove seal integrity. Seal verification is achieved without bleeding media to the atmosphere or the need to discharge product into a sump system.

BODY BLEED & THERMAL RELIEF VALVE OPTIONS



LR/DTR

Line Relieving Differential Thermal Relief (LR/DTR)

Solution to piping over pressurization in a liquid service.

This system performs the same function as the DTR system as well as protecting the piping system. When the DAN-EX valve is closed, piping is subject to thermal pressure buildup. The check valve located at the downstream port will relieve to the upstream port once there is a differential of 25 PSI. Extra isolation valves are included, to remain open, in the event a portion of the system requires replacement.

While this system is available and functional, Western Valve strongly recommends traditional thermal protection to relieve pipeline pressures around valves whenever possible.



DP SWITCH

Differential Pressure Switch (DTR) with Gauge

Solution for field maintenance to verify the valve is sealed from an external location via electrical connection.

The differential check valve relieves the body cavity pressure upstream, the same as in a standard DTR system. This protects the body from thermal expansion; the pressure equalizing check is there to keep the body cavity pressure from decreasing below 25 psi to prevent the differential pressure gauge from running out of range. The DP switch sends an electrical indication that will trigger a micro switch when the pressure differential has reached a customer requested set point. The set point is traditionally placed at 10 psi. The DP switch signals the control room that the valve has made seat. This minimizes maintenance efforts to manually verify DBB/DIB while in the field.

BODY BLEED & THERMAL RELIEF VALVE OPTIONS



ABBV

Automatic Body Bleed Valve (ABBV)

Solution to automatic verification of seal integrity in a liquid service.

This system automatically provides a seal integrity check when the DAN-EX valve is closed. In addition, thermal pressure buildups in the cavity are relieved.

A plunger actuated check valve is opened by the cam as the DAN-EX valve is closed. When the DAN-EX valve is opened, the ABBV is automatically closed. Typical application includes installation of a sight glass between the discharge piping and sump. *Note: discharge piping and sight glass is provided by others.*

EXTENSIONS

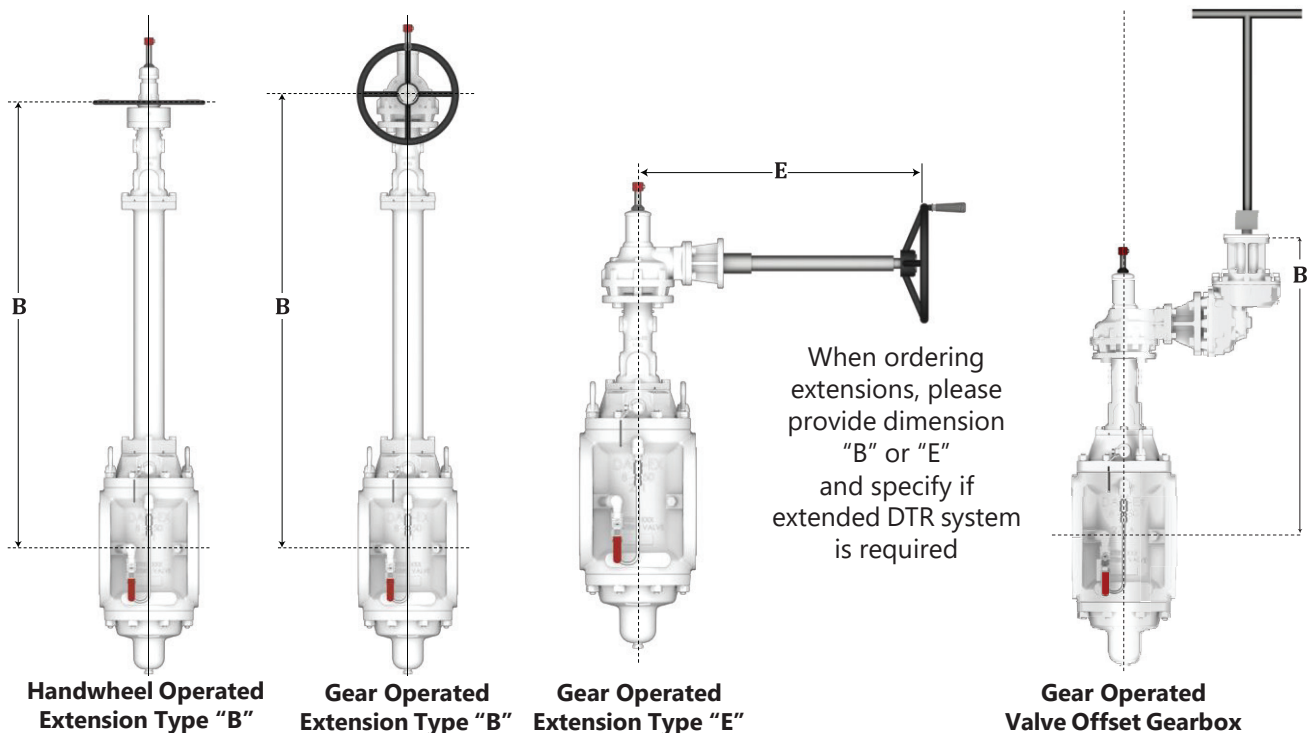

**Handwheel Operated
Extension Type "B"**

**Gear Operated
Extension Type "B"**

**Gear Operated
Extension Type "E"**

**Gear Operated
Valve Offset Gearbox**

Note: DAN-EX DTR systems are customizable for extensions allowing operator accessibility for seal verification. In addition, remote DTR systems can be customized at customer request.

ACTUATION

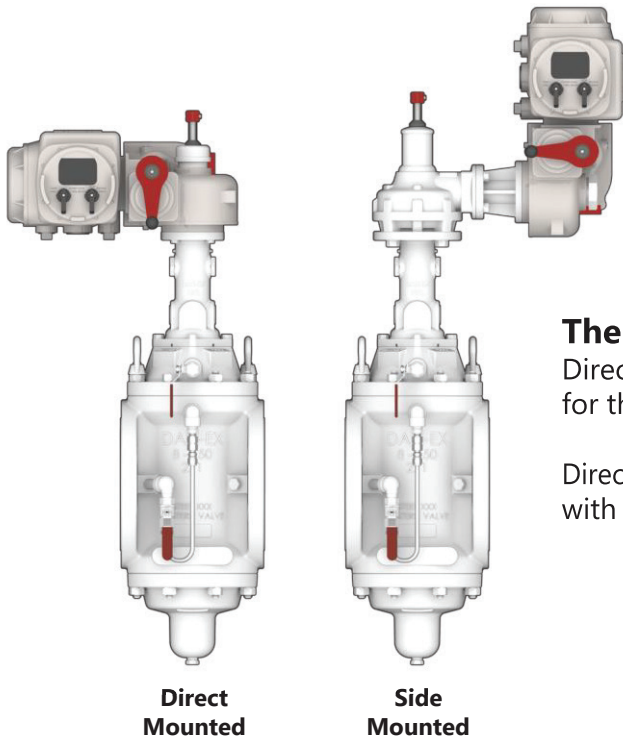

The DAN-EX valve provides two mounting options:

Direct mounted to operator or side mounted through bevel gear for the majority of electric motor operators.

Direct mounted actuation allows you to have faster closing speeds with lower RPM electric motor operators.

LIMIT SWITCHES

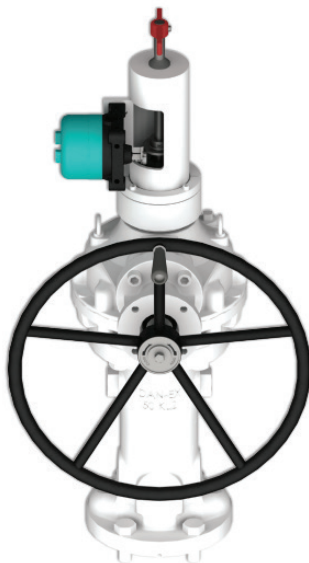

Limit Switches provide open/closed valve position indication.

- Weatherproof and Explosion proof
- Single Pole Double Throw (SPDT)
- Double Pole Double Throw (DPDT)

DAN-EX APPLICATIONS

Commercial and Military Aviation Fueling

DAN-EX valves are trusted worldwide at international and domestic airports to facilitate operation, leak detection, testing, maintenance, and fuel system repair. Zero leakage and verifiable engineering ensures system integrity during critical operations.

Equipment Isolation

API regulations require provable verification of shutoff before performed maintenance. Mechanically seated slips do not require external pressures to seal. Furthermore, the DAN-EX valve will not relieve any build up in body pressure to the downstream port.

Loading, Unloading, and Blending

Fuel and additive loading and unloading requires hundreds of cycles per day. The DAN-EX unique solid cam with roller type bearings can be driven fast and efficiently to perform this demanding application. Loading and unloading facilities around the world have trusted DAN-EX to seal 100% under fast and frequent cycles.

Multi-Product Pipeline Manifolds

The DAN-EX design, with two independent mechanically expanded slips, will seal 100% . Due to the non scoring of the seats due to the DANEX design, frequent cycling will not cause wear on the resilient seals, therefore providing years of reliable service.



DAN-EX APPLICATIONS CONT.

Metering and Measurement

DAN-EX provides zero leakage validation which is required during proving operations in flow meters. Closed DAN-EX valves separate different grades of gasoline, jet fuel, diesel, etc. Valve leakage in this critical application can cost millions if products are contaminated.

Refinery Shipping and Blending

After various product is refined, the remaining is transferred to storage tanks and delivered to customers via vessel, pipeline, barge and rail. DAN-EX valves provide zero leakage and verifiable aspects required to eliminate product contamination.

LPG

The DAN-EX slips and resilient seals are retracted away from the body during the plug rotation and mechanically expanded against the body until the resilient seals are compressed. The DAN-EX tight seal can be verified (DB&B) by opening the body bleed.

Tank Storage

Storage tanks can be exposed to contamination and/or loss of volume. DAN-EX valves are entrusted to ensure and verify zero leakage operations. DAN-Ex valves are used on tank farms, vessel loading wharfs, etc with the bleed valve opened for DB&B as well as left closed with the assurance of a tight shutoff with the body bleed valve closed.





Western Valve

Bakersfield, California



Western Valve is located in Bakersfield, California and has been privately owned and operated since 1991. What began as a valve repair and machine shop now features an impressive 65,000 square foot state-of-the-art manufacturing facility to support DAN-EX products and aftermarket remanufacturing worldwide. Celebrating our 34th year of customer service in the oil and gas industry.



Western Valve, Inc.

P.O. Box 10628, Bakersfield CA 93389
201 Industrial Street, Bakersfield CA 93307

Contact Us

Phone (661) 327-7660
Fax (661) 327-7734
sales@westernvalve.com

<http://www.westernvalve.com>

© 2023 - Western Valve, Inc. - All rights reserved.
Other products or services contained in this document may be registered trademarks of their respective companies.

Technical information contained or expressed in this brochure is subject to change or revision without notice. Western Valve, Inc. shall not be held liable for technical, publishing or editorial error or omissions. Western Valve, Inc. shall not be liable for damages resulting from the use of information contained within this document.

Please contact us for proper use, application, design or repair of any of our products.